



连续式混合机 CONTINUOUS MIXER



连续粉料混合
continuous powder mixing

连续颗粒混合
continuous granule mixing

连续粉加液
powder with liquid mixing

TEL: 86-021-69176576 69176577

上海市嘉定区南翔高科技园区 (胜辛南路399号)

Number 399, South Shengxin Road, Nanxiang High-tech Garden,
Jiading District, Shanghai City, China

升立机械
粉体技术实业专家

CN: WWW.1985MIXER.COM

EN: WWW.1985BLENDER.COM

SL@1985MIXER.COM

粉体连续式混合机原理有溢出法、进退补给法两种

溢出法：以控制出料为基础，于持续混合过程中，能在混合仓内形成并保持住一定量的填充料，这部分的物料与持续添加的物料进行混合，并进行更替叠加作用，使这部分物料一直保持着满足出料的条件，满溢而出。控制出料的方式可根据实际工艺以及物料的性质可做多种设计。

进退补给法：以搅拌器为基础，在混合仓内，搅拌器能够实现进料与退料同步或交替的作用力，根据混合工艺以及物料的性质，可采用多进少退、进退相等、少进多退的方式。

两种原理结合使用，确保了每一点的物料都经过了与设备筒内大部分物料相互掺混的过程，使产出的成品更具稳定性以及较高的混合均匀度。

连续混合方式通用添加液体或低精度混合的工况下采用。

Principle of continuous powder mixer:
overflow method, Advance and retreat supplies method.

Overflow method:
based on discharge control, certain amount of filler is kept in the mixer tank during the continuous mixing process, and this certain amount of filler is mixed with new filler, alternating and superimposing activity make this part of the material maintain the condition of discharge, material coming out with overflowing.

Advance and retreat supplies method:
based on the mixing agitator, agitator can achieve force of synchronous or alternating of feeding and retreat. Three methods, more feeding less retreat, less feeding more retreat, equal between feeding and retreat can be chosen based on the mixing process and nature of the materials.

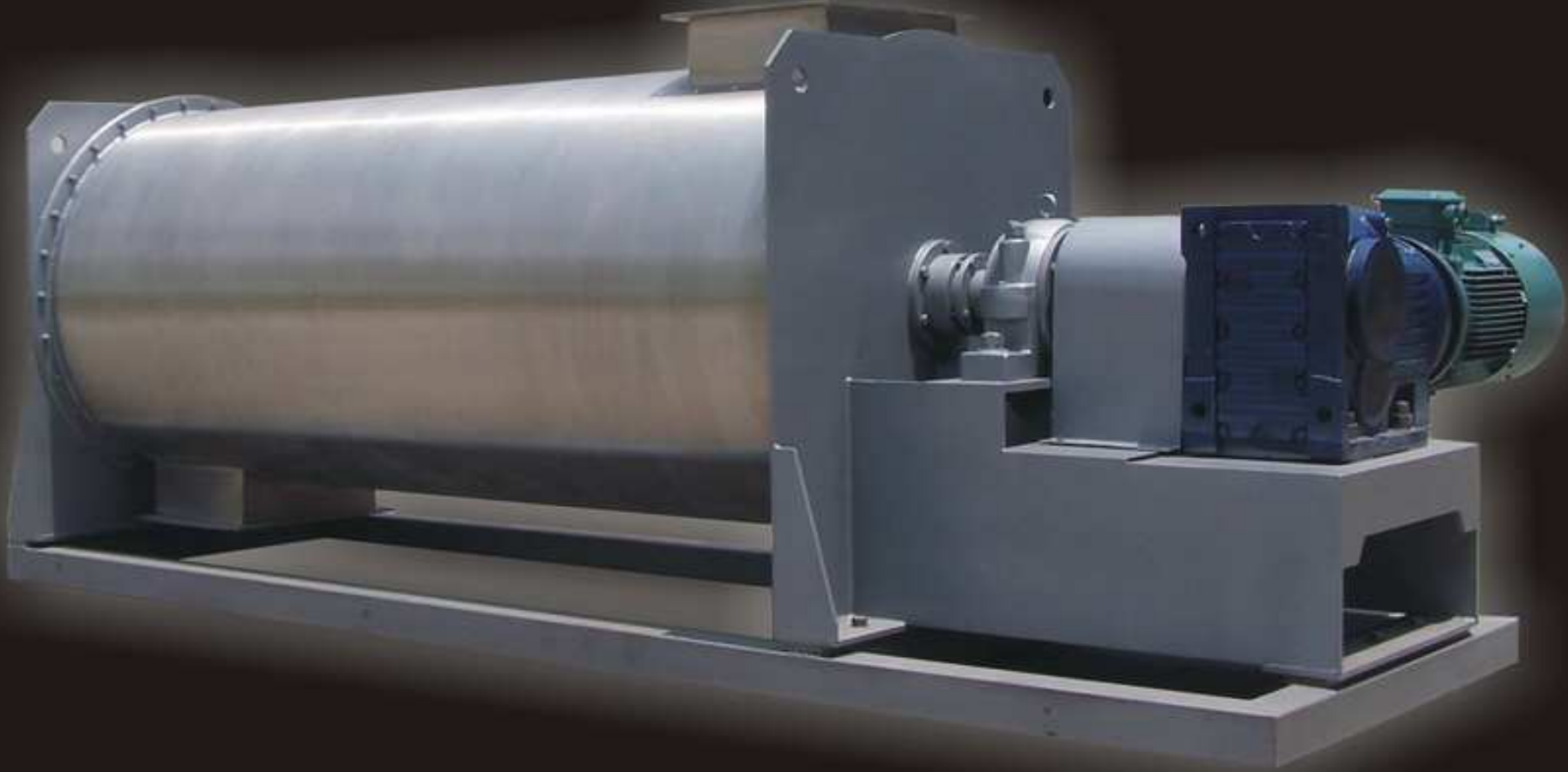

上海升立机械有限公司

LDHC连续式混合机

连续式混合机的使用要求:

- 1、喂料系统必须供料稳定且能不间断的供料。
- 2、各种物料的喂料速度必须成配方比例供料。
- 3、连续式混合机的下道工艺设备必须能够及时的处理连续式混合机排放的物料，不可造成堵料。
- 4、配方比例比较少的添加剂，如5%以下含量，在工艺设计上必须经过预混合，扩大含量比例后才能供料。
- 5、系统工艺的喂料速度决定了连续式混合机的产量，产量要求与混合均匀度以及物料的性质决定了混合设备的型号大小。

Working conditions of the continuous mixer

1. The material should be supplied steadily And continuously by the feeding system.
2. The feeding speed of different materials Should be subject to the formula proportion
3. The materials after mixing should be timely And efficiently processed by the next Equipment, any block here is forbidden
4. Little additive e.g. below 5% content should Be mixed with bulk material beforehand
5. The feeding speed decides the output of Continuous mixer, the output, uniformity and Properties of material decide the type and Size of mixer

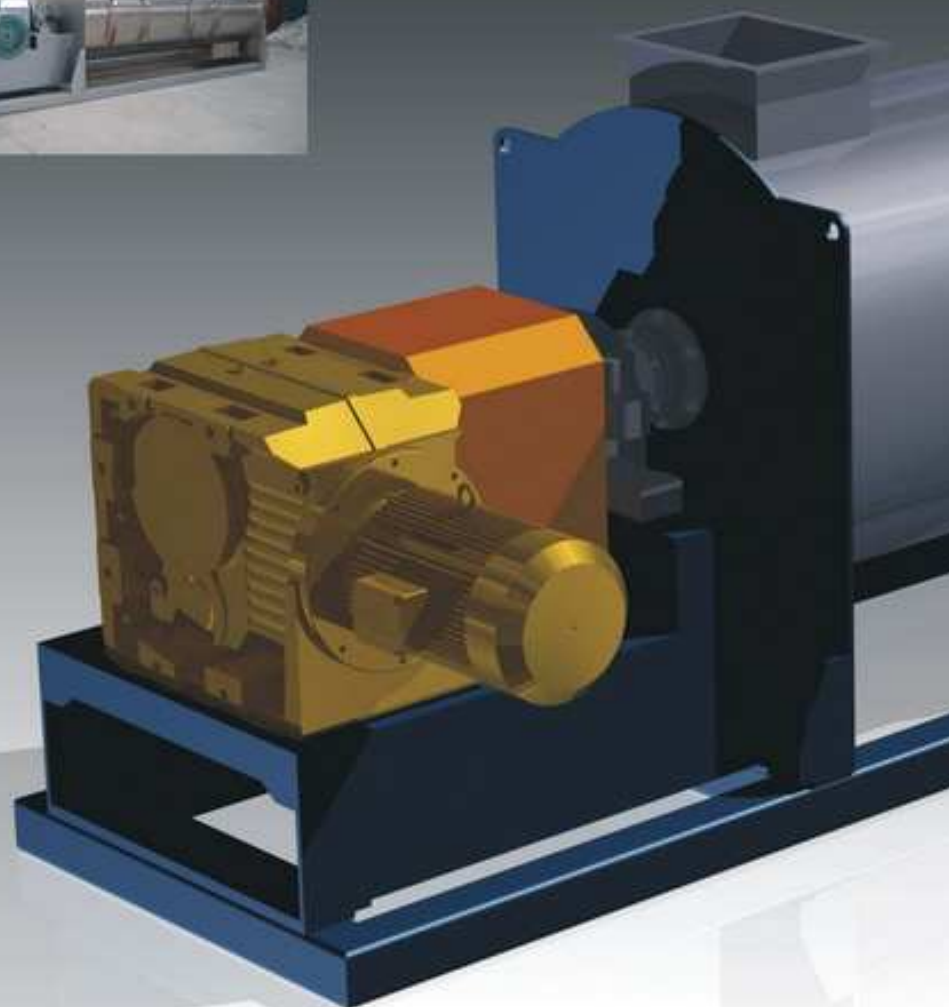

原料配仓 RAW MATERIAL SILO



成品仓 PRODUCT SILO

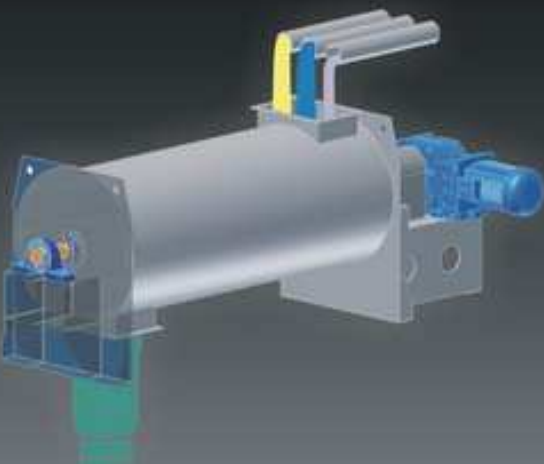
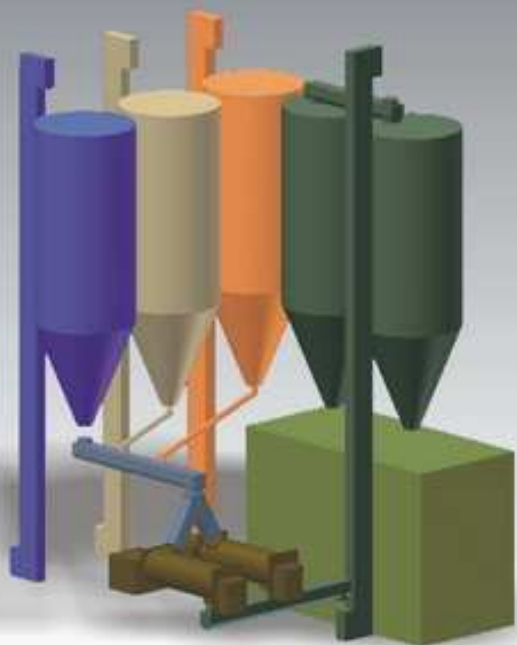

粉体连续式混合机的先驱者

LEADING MANUFACTURER OF POWDER CONTINUOUS MIXER

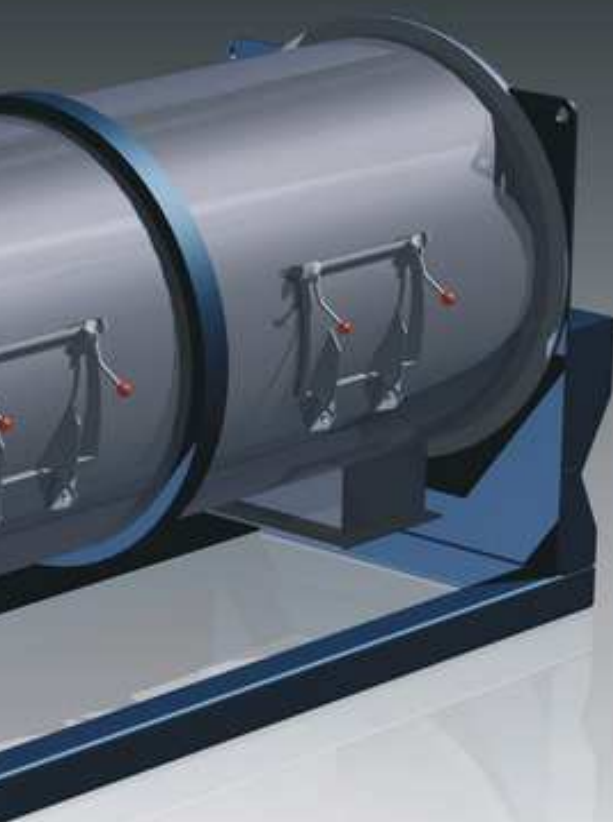
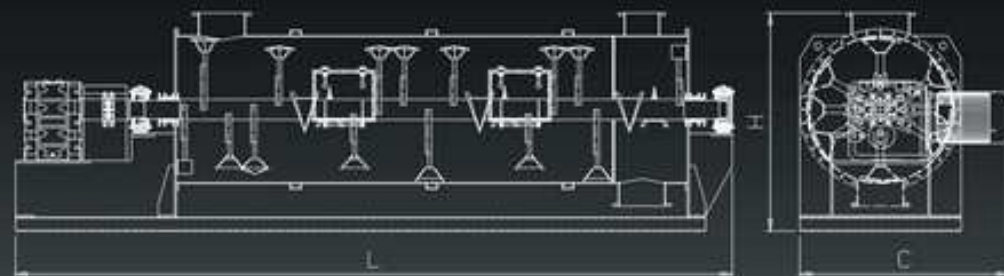

设备型号	全容积	最小使用容积	最大使用容积	最小适用产量	最大适用产量	功率	L	H	C	重量
TYPE	TOTAL VOLUME	MIN CAPACITY	MAX CAPACITY	MIN OUTPUT	MAX OUTPUT	POWER	L	H	C	WEIGHT
	L	L	L	T/H	T/H	KW	mm	mm	mm	KG
LDHC-500	500	100	250	2	6	7.5	3200	1200	1100	800
LDHC-1000	1000	200	500	5	15	11	3800	1350	1200	1200
LDHC-2500	2500	500	1250	10	30	22	4600	1680	1600	1600
LDHC-4000	4000	800	2000	20	60	37	5000	1860	1800	2600
LDHC-6000	6000	1200	3000	30	100	45	6000	2150	2350	3500
LDHC-10000	10000	2000	5000	50	150	75	6600	2400	2600	5500
LDHC-15000	15000	3000	7500	80	200	110	7000	2650	2900	8000



双桨叶式搅拌器

适用于含颗粒的连续混合物料，以及低粘度（具备流动性）的胶浆物料，以及液态物料

DOUBLE PADDLE AGITATOR

apply to continuously mix with powder and granule material, or low-sticky paste material or liquid material



犁刀式搅拌器

适用于多种粉体物料连续混合，以及不同批次的粉料进行连续混合。

PLOUGHSHARE AGITATOR

apply to continuously mix with different powder material and different batch materials.